

PROJECT: Helicopter Oil Cooling Fan Advanced Diagnostic

Goal: develop a health monitoring strategy which allow to perform preventive maintenance minimizing the downtime of the system and the costs.



Details of the unit under test:

- Nominal rotational speed: 21000 rpm
- Critical component: Front bearing
- Location on A/C: MGB
- Air temperature: Approx 100°C

Monitoring Instrumentation:

- Accelerometer (on top of the fan scroll)
- Thermocouple placed on front bearing

Qualification tests (experimental data collection):

- Fatigue test - 80000 cycles (10% for EFA)
- Overspeed test (up to 25486 rpm)
- Single blade loss test – Destructive test
- Endurance test – 2000H (10% for EFA)

Collaboration: Leonardo SpA

PROJECT: Helicopter Oil Cooling Fan Advanced Diagnostic

Causes of in-service failures:

- Front bearing failure
- Shaft misalignment (fan damage)

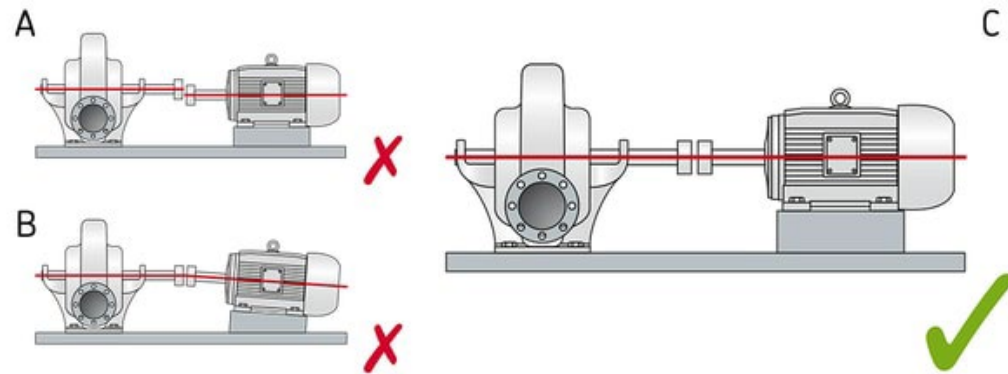

Objective: compute **Health Indexes (HI)** aimed at monitoring different failure modes of the components.

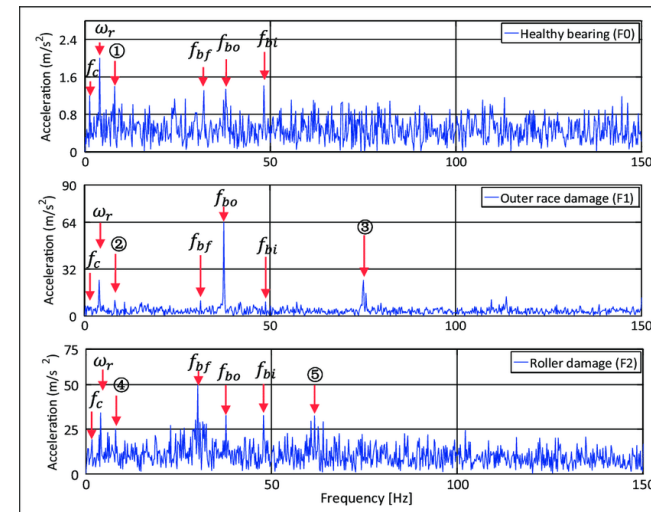
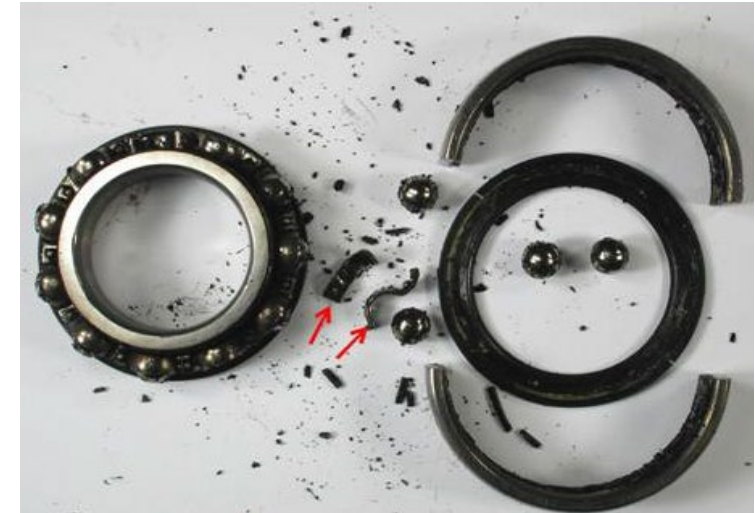

PROJECT: Helicopter Oil Cooling Fan Advanced Diagnostic

Title: Development of an advanced Health and Usage Monitoring System (HUMS) for a Cooling Fan

RESEARCH BACKGROUND:

Cooling fan Health and Usage Monitoring Systems (HUMS) use sensors to capture operational data and employ data analysis techniques and machine learning algorithms for real-time monitoring and condition-based maintenance. By detecting anomalies and early signs of failure, these systems enable proactive interventions and reduce the risk of unexpected fan failures. Integration with IoT and condition monitoring systems allows remote monitoring and timely interventions. Benefits include extended fan lifespan, optimized maintenance schedules, energy efficiency, and cost savings.

RESEARCH ACTIVITIES:

- Application of state-of-the-art pre-processing techniques to extract the health indicators from the available measurements (e.g., vibrations, temperature, sound pressure, shaft speed, etc.);
- Development of ML-algorithms for the fault diagnosis detection;
- Case study on a simple system's digital twin;
- Validation of the approach on real experimental data.

METHODOLOGY: numerical – experimental

DURATION: 9 months

CONTACTS:

claudio.sbarufatti@polimi.it

lorenzo.brancato@polimi.it

marco.giglio@polimi.it

